

RRD

YUVARLAK KESİCİ UÇLU TİP FREZELER
ÇOK YÖNLÜ PERFORMANS VE UZUN TAKIM ÖMRÜ



Mplus...

RRD

ÜRÜN ÖZELLİKLERİ



- Kalıp ve kalıp lokmalarını işlemek için yuvarlak kesici uçlu kesiciler
- 60 HRC'ye kadar işleme için çok yönlü kesici uç kalite aralığı
- Çok çeşitli kesiciler mevcuttur, malafa delikli, vida şaftlı, silindirik şaftlı ve weldon şaftlı tipler
- Çok çeşitli uç boyutları, R2.5, 3.5, 5.0, 6.0 ve 8.0

RRD

YUVARLAK KESİCİ UÇLU FREZELER

RRD FREZELER



ÖZELLİKLER

3 farklı toleransa sahip tüm uygulamalara uyacak şekilde kesici uçlar.

RDHX	RDZX	RDMX
<ul style="list-style-type: none"> Taşlanmış (Tolerans) Yüksek hassasiyet için Finiş öncesi ve finiş için 	<ul style="list-style-type: none"> Hassas sinterlenmiş (Tolerans) Üniversal kullanım için Uzun takım ömrüne sahip ekonomik kesici uç 	<ul style="list-style-type: none"> Sinterlenmiş (Tolerans) Üniversal kullanım için Kaba işleme ve finişe yakın işleme için
 <p>IC: ±0.013 mm S1: ±0.025 mm</p>	 <p>IC: ±0.025 mm S1: ±0.025 mm</p>	 <p>IC: ±0.05-±0.15 mm S1: ±0.13 mm</p>

KALİTEYE GENEL BAKIŞ

Aşınma direnci ↑	Kaplama Karbür					Kaplama Karbür	Kaplama Karbür			Kaplama Karbür	Kaplama Karbür			
	P	VP05HT	VP10H	VP15TF	VP20M	F7030	UT20T	K01	VP15TF	UT20T	H01	VP05HT	VP10H	VP15TF
P01														
P10														
P20														
P30														
P40														
Tokluk ↓														

RRD N

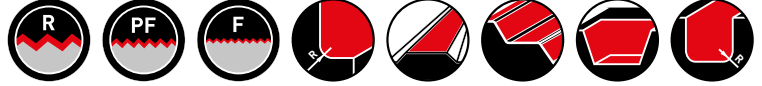

P K H

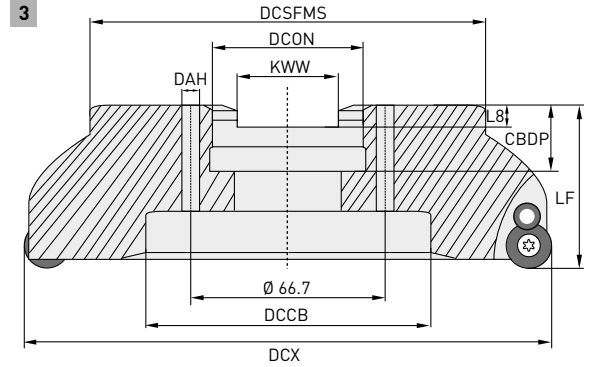
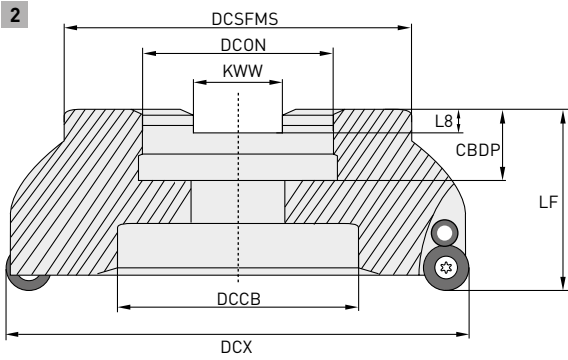
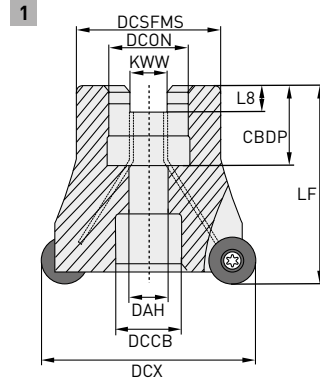

Yalnız sağ kesici

MALAFİ DELİKLİ TİP (Nötür)





Sipariş Numarası	Stok	APMX	DCX	DC	LF	DCON	CBDP	DAH	DCSFMS	KWW	L8	DCCB	ZEFP	Tip		
RRD050N-042A06R	●	5	42	32	44	16	18	9	33	8.4	5.7	15	6	○	1	RDH/M/Z
RRD050N-052A07R	●	5	52	42	50	22	20	11	44	10.4	6.3	18	7	○	1	1003M0
RRD060N-042A05R	●	6	42	30	42	16	18	9	33	8.4	5.7	15	5	○	1	
RRD060N-050A05R	●	6	50	38	50	22	20	11	44	10.4	6.3	18	5	○	1	RDH/M/Z
RRD060N-052A05R	●	6	52	40	50	22	20	11	44	10.4	6.3	18	5	○	1	12T3M0
RRD060N-063A06R	●	6	63	51	50	22	20	11	44	10.4	6.3	18	6	○	1	
RRD080N-050A04R	●	8	50	34	50	22	20	11	44	10.4	6.3	18	4	○	1	
RRD080N-052A04R	●	8	52	36	50	22	20	11	4	10.4	6.3	18	4	○	1	
RRD080N-052A05R	●	8	52	36	50	22	20	11	4	10.4	6.3	18	5	○	1	
RRD080N-063A05R	●	8	63	47	50	22	20	11	4	10.4	6.3	18	5	○	1	
RRD080N-066A05R	●	8	66	50	50	27	22	13.5	53	12.4	7.2	20	5	○	1	RDH/M/Z
RRD080N-080A06R	●	8	80	64	52	27	22	13.5	64	12.4	7.2	20	6	○	1	1604M0
RRD080N-100A07R	●	8	100	84	52	32	29	—	72	14.4	8	46	7	—	2	
RRD080N-125B08R	●	8	125	109	52	40	30	—	82	16.4	9	58	8	—	2	
RRD080N-160C09R	□	8	160	144	52	40	29	14	90	16.4	9	92	9	—	3	

1. ○ = İçten soğutma delikli



RRD N

YEDEK PARÇALAR

Sipariş Numarası	RE					
		Altlık	Altlık Vidası	Uç sıkma Vidası	Kesici Uç Sıkma Vidası	Anahtar
RRD050N-	042A06R	5			—	
	052A07R					
RRD060N-	042A05R	6	—	B-TS35	TS1001	TKY15F
	050A05R					
	052A05R					
	063A06R					
RRD080N-	050A04R	8	KS-12	B-TS45	214	—
	052A04R					
	052A05R					
	063A05R					
	066A05R					
	080A06R					
	100A07R					
125B08R						
160C09R						

RRD P

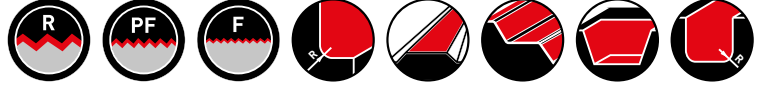

P K H

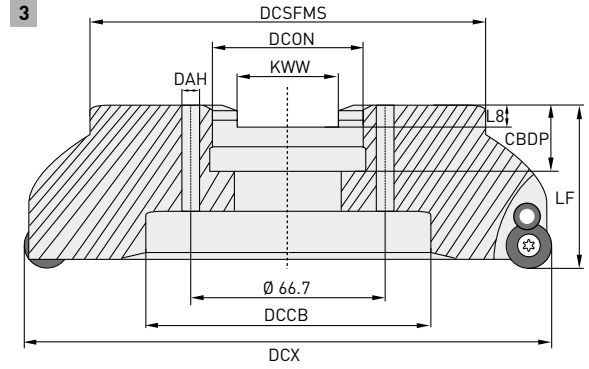
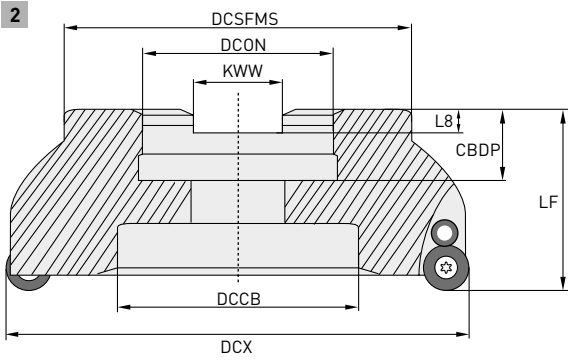
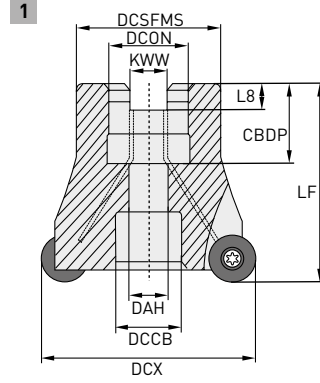

Yalnız sağ kesici





MALAFİ DELİKLİ TİP

Sipariş Numarası	Stok	APMX	DCX	DC	LF	DCON	CBDP	DAH	DCSFMS	KWW	L8	DCCB	ZİFP	Tip
RRD060P-050A05R	●	6	50	38	50	22	20	11	44	10.4	6.3	18	5	○ 1
RRD060P-052A05R	●	6	52	40	50	22	20	11	44	10.4	6.3	18	5	○ 1
RRD060P-063A06R	●	6	63	51	50	22	20	11	44	10.4	6.3	18	6	○ 1
RRD060P-066A06R	●	6	66	54	52	27	22	13.5	53	12.4	7.2	20	6	○ 1
RRD060P-080A07R	●	6	80	68	50	27	22	13.5	64	12.4	7.2	20	7	○ 1
RRD080P-050A04R	●	8	50	34	50	22	20	11	44	10.4	6.3	18	4	○ 1
RRD080P-063A05R	●	8	63	47	50	22	20	11	44	10.4	6.3	18	5	○ 1
RRD080P-066A05R	●	8	66	50	50	27	22	13.5	53	12.4	7.2	20	5	○ 1
RRD080P-080A06R	●	8	80	64	52	27	22	13.5	64	12.4	7.2	20	6	○ 1
RRD080P-100A07R	●	8	100	84	52	32	29	—	72	14.4	8	46	7	— 2
RRD080P-125B08R	●	8	125	109	52	40	30	—	82	16.4	9	58	8	— 2
RRD080P-160C09R	●	8	160	144	52	40	29	14	90	16.4	9	92	9	— 3

1. ○ = İçten soğutma delikli

15

RRD P**YEDEK PARÇALAR**

Sipariş Numarası	RE						
		Altık	Altık Vidası	Uç sıkma Vidası	Kesici Uç Sıkma Vidası	Anahtar	
RRD060P-	050A05R	6	—	—	B-TS35	TS1001	TKY15F
	052A05R						
	063A06R						
	066A06R						
	080A07R						
RRD080P-	050A04R	8	KS-12	B-TS45	214	—	TKY20F
	063A05R						
	066A05R						
	080A06R						
	100A07R						
	125B08R						
160C09R							

RRD

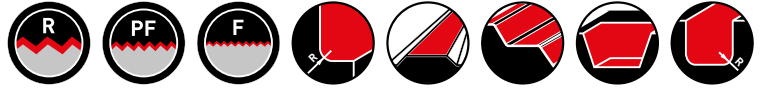

P K H

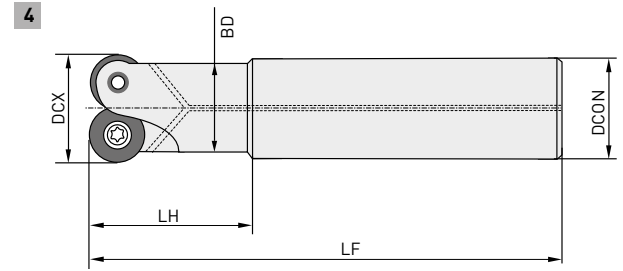
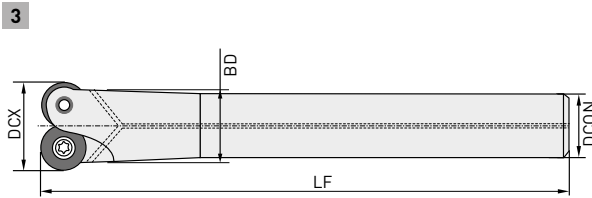
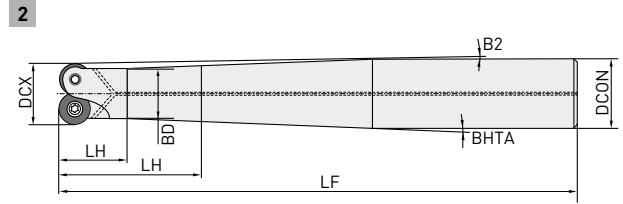
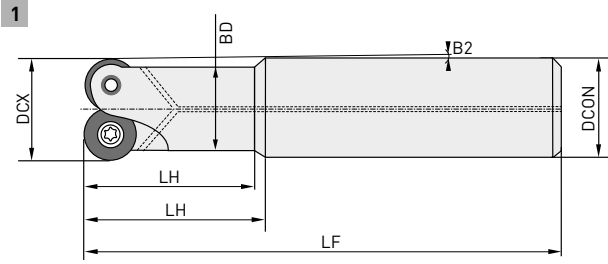





Yalnız sağ kesici.

SİLİNDİRİK ŞAFTLI TİP

Sipariş Numarası	Stok	APMX	DCX	DCON	LF	LU	LH	BD	B2	BHTA	ZEFP	Tip	
RRD025R102S10Z	●	2.5	10	10	75	—	23	—	—	0.89	2	4	RDH/Z 0501M0
RRD025R123S12Z	●	2.5	12	12	75	—	23	11	—	—	3	4	
RRD025R154S16Z	●	2.5	15	16	80	22	22.5	14	1.4	45	4	1	
RRD035R122S10Z	●	3.5	12	10	75	23	—	11	—	—	2	3	RDH/M/Z 07T1M0
RRD035R122S12Z	●	3.5	12	12	75	—	23	11	—	—	2	4	
RRD035R122S16Z	□	3.5	12	16	88	15	18.4	11	4	8.37	2	2	
RRD035R122S16ZL	●	3.5	12	16	128	15	22.4	11	2.36	3.87	2	2	RDH/M/Z 0702M0
RRD035R122S16ZM	●	3.5	12	16	109	15	22.4	11	2.36	3.87	2	2	
RRD035R152S16Z	□	3.5	15	16	88	18	27.6	14	1	6.52	2	2	
RRD035R152S16ZM	●	3.5	15	16	108	18	41.4	14	0.59	2.69	2	2	RDH/M/Z 0702M0
RRD035R152S20Z	●	3.5	15	20	130	20	35.6	14	2.12	4.04	2	2	
RRD035R152S20ZM	●	3.5	15	20	150	20	41.7	14	1.64	2.9	2	2	
RRD035R152S25Z	□	3.5	15	25	176	20	36.8	14	2.64	3.8	2	2	RDH/M/Z 07T1M0
RRD035R153S12Z	□	3.5	15	12	75	17	—	12.8	—	—	3	3	
RRD035R153S16Z	□	3.5	15	16	78	29.5	30	14	1.08	45	3	1	
RRD050R202S20Z	●	5	20	20	90	—	31	18	—	—	2	4	RDH/M/Z 1003M0
RRD050R202S20ZM	●	5	20	20	110	—	51	18	—	—	2	4	
RRD050R202S25Z	●	5	20	25	136	68.5	69.5	18	2.13	45	2	1	
RRD050R202S25ZL	●	5	20	25	176	108.5	109.5	18	1.34	45	2	1	RDH/M/Z 1003M0
RRD050R202S25ZM	●	5	20	25	156	88.5	89.5	18	1.64	45	2	1	

RRD

YEDEK PARÇALAR

Sipariş Numarası	RE						
		Altık	Altık Vidası	Uç sıkma Vidası	Kesici Uç Sıkma Vidası	Anahtar	
RRD025R-	102S10Z						
	123S12Z	2.5	—	—	B-TS20	—	TKY06F
	54S16Z						
RRD035R-	122S10Z						
	122S12Z						
	122S16Z	3.5	—	—	B-TS253	—	TKY07F
	122S16ZL						
	122S16ZM						
	152S16Z						
	152S16ZM						
	152S20Z		—	—	TS25	—	TKY08F
	152S20ZM						
	152S25Z						
RRD050R-	153S12Z		—	—	TS253	—	TKY08F
	153S16Z						
	202S20Z						
	202S20ZM						
	202S25Z	5	—	—	B-TS35	—	TKY15F
	202S25ZL						
	202S25ZM						

RRD

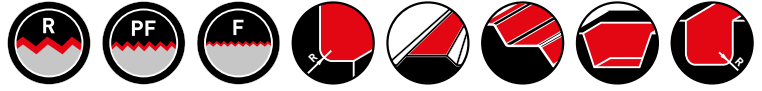

P K H

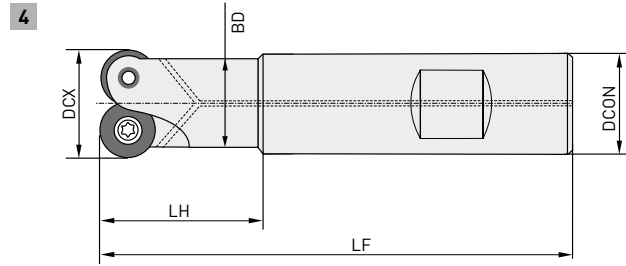
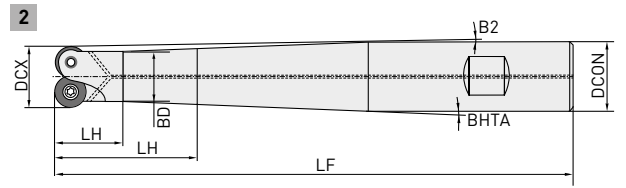
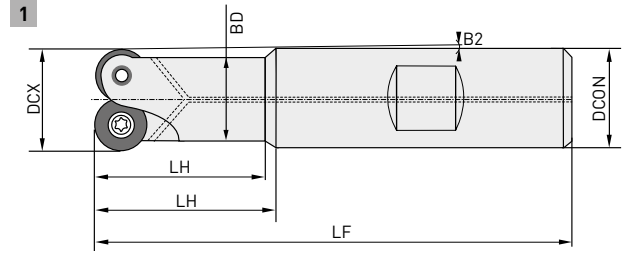





Yalnız sağ kesici.

WELDON ŞAFTLI TİP

Sipariş Numarası	Stok	APMX	DCX	DCON	LF	LU	LH	BD	B2	BHTA	ZEFP	Tip	
RRD035R122S16W	●	3.5	12	16	88	15	18.4	11	4	8.37	2	2	RDH/M/Z 07T1M0
RRD035R122S16WL	●	3.5	12	16	128	15	22.4	11	2.36	3.87	2	2	
RRD035R122S16WM	□	3.5	12	16	108	15	22.4	11	2	3.87	2	2	
RRD035R152S16W	□	3.5	15	16	88	18	27.6	12.8	1	6.52	2	2	RDH/M/Z 0702M0
RRD035R152S16WM	□	3.5	15	16	108	18	41.38	12.8	0.59	2.69	2	2	
RRD035R152S20W	□	3.5	15	20	130	20	35.58	12.8	2.12	4.04	2	2	
RRD035R152S20WM	□	3.5	15	20	150	20	41.7	12.8	1.64	2.9	2	2	RDH/M/Z 07T1M0
RRD035R152S25W	□	3.5	15	25	176	20	36.8	12.8	3.8	2.65	2	2	
RRD035R153S16W	□	3.5	15	16	78	28.4	29.5	12.8	1.08	45	3	1	
RRD050R202S20W	●	5	20	20	90	—	31	18	—	—	2	4	RDH/M/Z 1003M0
RRD050R202S20WM	●	5	20	20	110	—	51	18	—	—	2	4	
RRD050R202S25W	●	5	20	25	136	23	37	18	2.13	4.09	2	2	
RRD050R202S25WL	□	5	20	25	176	47.6	23	18	1.34	2.25	2	2	RDH/M/Z 1003M0
RRD050R202S25WM	□	5	20	25	156	42.7	23	18	1.64	2.9	2	2	

RRD

YEDEK PARÇALAR

Sipariş Numarası	RE						
		Altlık	Altlık Vidası	Uç sıkma Vidası	Kesici Uç Sıkma Vidası	Anahtar	
	122S16W						
	122S16WL	—	—	B-TS253	—	TKY07F	
	122S16WM						
RRD035R-	152S16W						
	152S16WM	3.5					
	152S20W			TS25		TKY08F	
	152S20WM	—	—		—		
	152S25W						
	153S16W			TS253			
RRD050R-	202S20W						
	202S20WM						
	202S25W	5	—	—	B-TS35	—	TKY15F
	202S25WL						
	202S25WM						

RRD

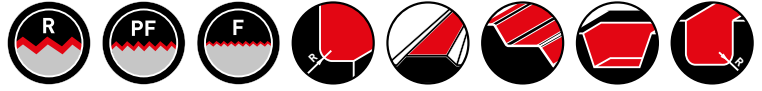

P K H

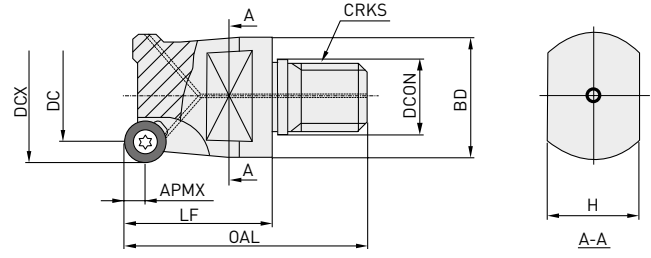





Yalnız sağ kesici.

VİDA ŞAFTLI TİP

Sipariş Numarası	Stok	APMX	DCX	DC	OAL	LF	DCON	DCSFMS	CRKS	H	ZEFP	
RRD025R102M5	□	2.5	10	5	35	20	5.5	9.9	M5	6	2	
RRD025R123M8	●	2.5	12	7	38	20	8.5	13.5	M8	9	3	RDH/Z 0501M0
RRD025R154M8	●	2.5	15	10	38	20	8.5	13.5	M8	10	4	
RRD025R205M10	●	2.5	20	15	44	25	10.5	18	M10	15	5	
RRD035R122M8	●	3.5	12	5	46	28	8.5	13.5	M8	9	2	
RRD035R153M8	●	3.5	15	8	46	28	8.5	13.5	M8	10	3	
RRD035R204M10	●	3.5	20	13	47	28	10.5	18	M10	15	4	RDH/M/Z 07T1M0
RRD035R255M12	●	3.5	25	18	50	28	12.5	21	M12	17	5	
RRD035R306M16	●	3.5	30	23	51	28	17	29	M16	22	6	
RRD035R357M16	●	3.5	35	28	51	28	17	29	M16	22	7	
RRD035R152M8	●	3.5	15	8	46	28	8.5	13.5	M8	10	2	RDH/M/Z 0702M0
RRD035R153M8X	●	3.5	15	8	43	28	8.5	13.5	M8	10	3	
RRD050R202M10	●	5	20	10	47	28	10.5	18	M10	15	2	
RRD050R252M12	●	5	25	15	54	32	12.5	21	M12	17	2	
RRD050R253M12	●	5	25	15	54	32	12.5	21	M12	17	3	
RRD050R304M12	●	5	30	20	54	32	12.5	21	M12	17	4	RDH/M/Z 1003M0
RRD050R304M16	●	5	30	20	55	32	17	29	M16	22	4	
RRD050R355M16	●	5	35	25	65	42	17	29	M16	22	5	
RRD050R426M16	●	5	42	32	65	42	17	29	M16	22	6	
RRD060R242M12	●	6	24	12	54	32	12.5	21	M12	17	2	
RRD060R353M16	●	6	35	23	65	42	17	29	M16	22	3	
RRD060R354M16	●	6	35	23	65	42	17	29	M16	22	4	RDH/M/Z 12T3M0
RRD060R424M16	●	6	42	30	55	32	17	29	M16	24	4	
RRD060R425M16	●	6	42	30	65	42	17	29	M16	22	5	
RRD080R322M16	●	8	32	16	65	42	17	29	M16	22	2	RDH/M/Z 1604M0

YEDEK PARÇALAR

Sipariş Numarası	RE							
		Altılık	Altılık Vidası	Uç sıkma Vidası	Kesici Uç Sıkma Vidası	Anahtar		
RRD025R-	102M5	2.5	—	—	B-TS20	—	TKY06F	
	123M8							
	154M8							
	205M10							
RRD035R-	122M8	3.5	—	—	B-TS253	—	TKY07F	
	153M8							
	204M10							
	255M12				TS253			
	306M16							
	357M16							
	152M8				TS25			—
153M8X								
RRD050R-	202M10	5	—	—	B-TS35	—	TKY15F	
	252M12							
	253M12							
	304M12							
	304M16							
	355M16							
426M16								
RRD060R-	242M12	6	—	—	B-TS35	—	TKY15F	
	353M16							
	354M16							TS1001
	424M16							
425M16								
RRD080R-	322M16	8	—	—	214	—	TKY20F	

KESİCİ UÇLAR

P	Çelik	●	●	●	●	●	●
K	Dökme Demir		✘	✘	✘	✘	✘
H	Sertleştirilmiş Çelik		●	●	●	●	●

Kesme Koşulları:

●: Düz Kesme ●: Genel Kesme ✘: Darbeli Kesme

Sipariş Numarası	Sınıf	Honlama	F7030	VP15TF	VP20M	VP10H	VP05HT	UTi20T	IC	S
RDHX0501M0E	H	E	●	●		●	●		5	1.5
RDHX0501M0S	H	S	●	●		●			5	1.5
RDHX07T1M0E	H	E	●	●		●	●		7	1.98
RDHX07T1M0S	H	S	●	●		●	●		7	1.98
RDHX0702M0E	H	E	●	●		●	●		7	2.38
RDHX0702M0S	H	S	●	●		●			7	2.38
RDHX1003M0E	H	E	●	●		●	●		10	3.18
RDHX1003M0S	H	S	●	●		●	●		10	3.18
RDHX12T3M0E	H	E	●	●		●	●		12	3.97
RDHX12T3M0S	H	S	●	●		●			12	3.97
RDHX1604M0E	H	E	●	●		●	●		16	4.76
RDHX1604M0S	H	S	●	●		●			16	4.76
RDMX07T1M0E	M	E					●		7	1.98
RDMX07T1M0T	M	T	●	●	●				7	1.98
RDMX0702M0E	M	E					●		7	2.38
RDMX0702M0T	M	T	●	●	●		□		7	2.38
RDMX1003M0E	M	E					●		10	3.18
RDMX1003M0S	M	S		●	●				10	3.18
RDMX1003M0T	M	T	●	●	●		●		10	3.18
RDMX12T3M0E	M	E					●		12	3.97
RDMX12T3M0S	M	S		●	●				12	3.97
RDMX12T3M0T	M	T	●	●	●		●		12	3.97
RDMX1604M0E	M	E					●		16	4.76
RDMX1604M0S	M	S		●	●				16	4.76
RDMX1604M0T	M	T	●	●	●		●		16	4.76
RDZX0501M0E	Z	E		●					5	1.50
RDZX07T1M0E	Z	E		●					7	1.98
RDZX0702M0E	Z	E		●					7	2.38
RDZX1003M0E	Z	E		●					10	3.18
RDZX1003M0S	Z	S	●	●					10	3.18
RDZX12T3M0E	Z	E		●					12	3.97
RDZX12T3M0S	Z	S	●	●					12	3.97
RDZX1604M0E	Z	E		●					16	4.76
RDZX1604M0S	Z	S	●	●					16	4.76

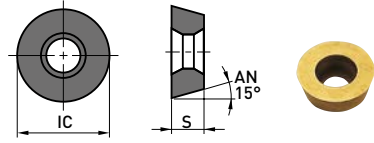

IC: ±0.013 mm S: ±0.025 mm

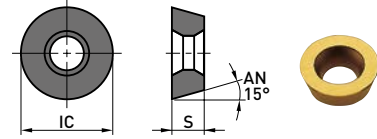

IC: ±0.05-±0.15 mm S: ±0.15 mm

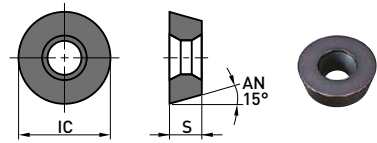

IC: ±0.025 mm S: ±0.025 mm

KESME KENARI YAPISI

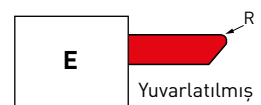
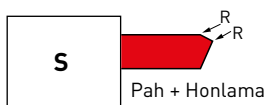

● Kaba işleme için

● Kaba ve Finit işleme için

● Finit işleme için

RRD

ÖNERİLEN KESME KOŞULLARI

KABA İŞLEME İÇİN KESME KOŞULLARI (ae = %50 Ø)

İş parçası Malzemesi	Sertlik	Kalite	Vc	Ø 10-15 mm		Ø 20 mm		Ø 24-25 mm		Ø 30-42 mm		Ø 50-80 mm		Ø 100-160 mm	
				ap	fz	ap	fz	ap	fz	ap	fz	ap	fz	ap	fz
P Yumuşak Çelik	<180HB	F7030 VP15TF	[250-320]	-0.2	0.25	-0.5	0.45	-1.0	0.35	-1.0	0.40	-1.0	0.50	-1.5	0.60
			[240-300]	0.2-0.3	0.20	0.5-1.0	0.25	1.0-2.0	0.30	1.5-2.0	0.32	1.0-1.5	0.40	1.5-2.5	0.45
			[200-280]	0.3-0.5	0.12	1.0-1.5	0.15	2.0-2.5	0.20	2.0-3.0	0.25	1.5-3.0	0.35	2.5-5.0	0.35
Karbon Çeliği Alaşımlı Çelik	180- 350HB	F7030 VP15TF	[220-300]	-0.2	0.20	-0.5	0.40	-1.0	0.30	-1.0	0.40	-1.0	0.50	-1.5	0.55
			[200-290]	0.2-0.3	0.15	0.5-1.0	0.20	1.0-1.5	0.25	1.5-2.0	0.30	1.0-1.5	0.38	1.5-2.5	0.40
			[160-250]	0.3-0.5	0.10	1.0-1.5	0.10	1.5-2.0	0.22	2.0-3.0	0.22	1.5-3.0	0.30	2.5-4.5	0.32
K Dökme Demir	Kopma Mukavemeti <450 MPa	VP15TF VP20M VP10H	[200-250]	-0.1	0.15	-0.5	0.18	-1.0	0.20	-1.0	0.25	-1.0	0.30	-1.5	0.35
			[180-230]	0.1-0.2	0.10	0.5-1.0	0.10	1.0-1.5	0.15	1.5-2.0	0.18	1.0-1.5	0.25	1.5-2.5	0.22
			[160-200]	0.2-0.25	0.10	1.0-1.5	0.10	1.5-2.0	0.12	2.0-3.0	0.15	1.5-3.0	0.18	2.5-4.5	0.20
H Sertleştirilmiş Çelik	-52HRC -58HRC -60HRC	VP15TF VP10H VP05HT	[140-200]	-0.1	0.12	-0.1	0.14	-0.1	0.15	-0.1	0.18	-0.1	0.18	-0.1	0.20
			[110-180]	0.1-0.15	0.10	0.1-0.20	0.12	0.1-0.30	0.12	0.1-0.30	0.14	0.1-0.30	0.14	0.1-0.30	0.15
			[100-170]	0.1-0.15	0.10	0.1-0.20	0.10	0.1-0.30	0.10	0.1-0.30	0.12	0.1-0.30	0.12	0.1-0.30	0.12

1. Takımın tam kesme genişliği kullanıldığında lütfen kesme koşullarını %20 oranında düşürün.
2. Takım boyu uzun kullanıldığında lütfen ilerleme oranını %20 düşürün.

FİNİŞ İŞLEME İÇİN KESME KOŞULLARI (ae = %20 Ø)

İş parçası Malzemesi	Sertlik	Kalite	Vc	Ø 10-15 mm		Ø 20 mm		Ø 24-25 mm		Ø 30-42 mm		Ø 50-80 mm		Ø 100-160 mm	
				ap	fz	ap	fz	ap	fz	ap	fz	ap	fz	ap	fz
P Yumuşak Çelik	<180HB	F7030 VP15TF	[260-360]	-0.1	0.15	-0.15	0.20	-0.15	0.25	-0.15	0.30	-0.15	0.32	-0.3	0.35
			[240-320]	0.1-0.2	0.15	0.1-0.2	0.15	0.1-0.2	0.18	0.1-0.3	0.20	0.1-0.3	0.22	0.2-0.3	0.25
			[220-280]	0.2-0.24	0.10	0.1-0.30	0.15	0.1-0.30	0.18	0.1-0.30	0.20	0.2-0.30	0.20	0.3-0.40	0.20
Karbon Çeliği Alaşımlı Çelik	180- 350HB	F7030 VP15TF	[250-350]	-0.1	0.12	-0.1	0.15	-0.1	0.18	-0.1	0.25	-0.1	0.28	-0.15	0.30
			[230-310]	0.1-0.15	0.12	0.1-0.30	0.15	0.1-0.30	0.15	0.1-0.30	0.20	0.1-0.3	0.22	0.15-0.3	0.25
			[210-270]	0.15-0.2	0.10	0.15-0.30	0.12	0.15-0.30	0.15	0.15-0.30	0.15	0.2-0.3	0.18	0.2-0.3	0.18
K Dökme Demir	Kopma Mukavemeti <450 MPa	VP15TF VP20M VP10H	[200-300]	-0.1	0.15	-0.1	0.18	-0.1	0.20	-0.1	0.22	-0.1	0.25	-0.15	0.30
			[200-280]	0.1-0.2	0.10	0.1-0.30	0.10	0.1-0.3	0.15	0.1-0.3	0.15	0.1-0.3	0.20	0.15-0.3	0.22
			[180-240]	0.2-0.25	0.10	0.2-0.40	0.10	0.2-0.4	0.12	0.2-0.4	0.12	0.2-0.4	0.15	0.2-0.4	0.18
H Sertleştirilmiş Çelik	-52HRC -58HRC -60HRC	VP15TF VP10H VP05HT	[150-200]	-0.1	0.15	-0.1	0.14	-0.1	0.15	-0.1	0.18	-0.1	0.18	-0.1	0.20
			[120-180]	0.1-0.15	0.10	0.1-0.20	0.12	0.1-0.30	0.12	0.1-0.30	0.14	0.1-0.30	0.14	0.1-0.30	0.15
			[100-180]	0.1-0.15	0.10	0.1-0.20	0.10	0.1-0.30	0.10	0.1-0.30	0.12	0.1-0.30	0.12	0.1-0.30	0.12

1. Takımın tam kesme genişliği kullanıldığında lütfen kesme koşullarını %20 oranında düşürün.
2. Takım boyu uzun kullanıldığında lütfen ilerleme oranını %20 düşürün.



GERMANY

MMC HARTMETALL GMBH
Comeniusstr. 2 . 40670 Meerbusch
Phone +49 2159 91890 . Fax +49 2159 918966
Email admin@mmchg.de

U.K.

MMC HARDMETAL U.K. LTD.
Mitsubishi House . Galena Close . Tamworth . Staffs. B77 4AS
Phone +44 1827 312312 . Fax +44 1827 312314
Email sales@mitsubishicarbide.co.uk

SPAIN

MITSUBISHI MATERIALS ESPAÑA, S.A.
Calle Emperador 2 . 46136 Museros/Valencia
Phone +34 96 1441711 . Fax +34 96 1443786
Email comercial@mmevalencia.es

FRANCE

MMC METAL FRANCE S.A.R.L.
6, Rue Jacques Monod . 91400 Orsay
Phone +33 1 69 35 53 53 . Fax +33 1 69 35 53 50
Email mmfsales@mmc-metal-france.fr

POLAND

MMC HARDMETAL POLAND SP. Z O.O
Al. Armii Krajowej 61 . 50-541 Wrocław
Phone +48 71335 1620 . Fax +48 71335 1621
Email sales@mitsubishicarbide.com.pl

RUSSIA

MMC HARDMETAL OOO LTD.
Electrozavodskaya St. 24 . build. 3 . Moscow . 107023
Phone +7 495 725 58 85 . Fax +7 495 981 39 79
Email info@mmc-carbide.ru

ITALY

MMC ITALIA S.R.L.
Viale Certosa 144 . 20156 Milano
Phone +39 0293 77031 . Fax +39 0293 589093
Email info@mmc-italia.it

TURKEY

MMC HARTMETALL GMBH ALMANYA - İZMİR MERKEZ ŞUBESİ
Adalet Mahallesi Anadolu Caddesi No: 41-1 . 15001 35530 Bayraklı /İzmir
Phone +90 232 5015000 . Fax +90 232 5015007
Email info@mmchg.com.tr

www.mitsubishicarbide.com | www.mmc-hardmetal.com

DAĞITICI:

□

□

L

┘

Sipariş Kodu: B087TR 

Yayın Tarihi: 2022.04 (0), Almanya'da basılmıştır